

Orifice Flange B16.36

CLASS 300 FLANGES

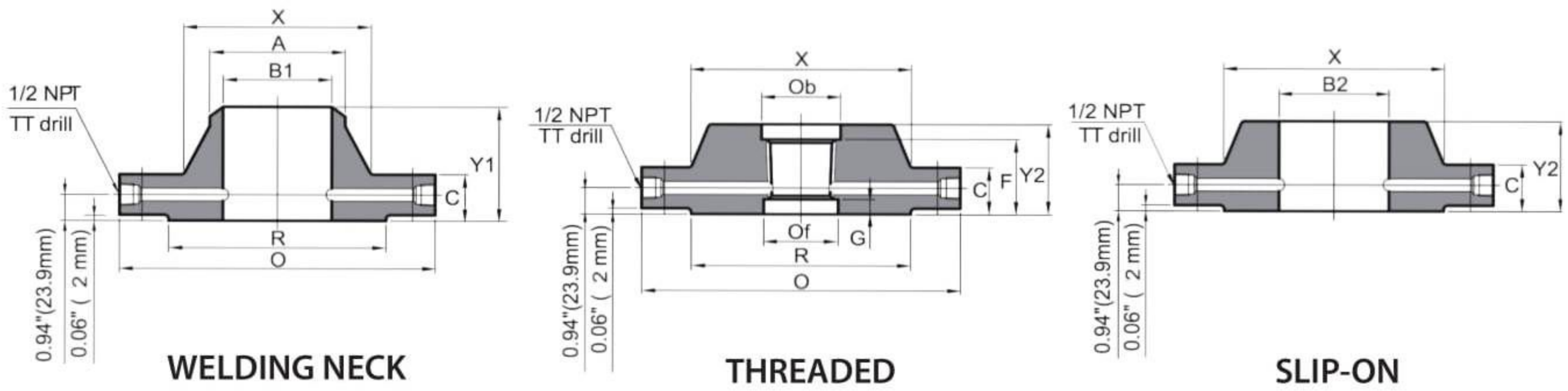

Unit : mm

Nominal Pipe Size	O.D of Raised Face	O.D of Flange	Thick-ness of Min. Flange	Length Through Hub		Diam. Of Hub	Diam. of Hub at Bevel	Length Through Hub				Bore		Diam. of Pressure Connection (inch)	Drilling Template			Length of Stud Bolts
				Slip-on & Threaded	Welding Neck			Back	face	Counterbore Depth (From Face)	Slip-on	Wedling Neck	Bolt Circle Diam.		Number of Holes	Diam. Of Holes		
																	Y2	
1	50.8	125	36.6	46	81	54	33.4	35.8	33	36.5	19	34.5	To be Specified by Purchaser	1/4	88.9	4	17.5	125
1 1/2	73	155	36.6	46	84	70	48.3	50.5	48	37.3	18.3	49.5		1/4	114.3	4	20.6	135
2	92.1	165	36.6	48	84	84	60.3	63.5	59.9	38.1	17.5	61.9		1/4	127	8	17.5	125
2 1/2	104.8	190	36.6	49	87	100	73	76.2	72.1	44.4	14.3	74.6		1/4	149.2	8	20.6	135
3	127	210	36.6	51	87	117	88.9	92.2	87.9	46	14.3	90.7		3/8	168.3	8	20.6	135
4	157.2	255	36.6	52	90	146	114.3	117.6	113	47.6	14.3	116.1		1/2	200	8	20.6	135
6	215.9	320	36.6	52	98	206	168.3	171.4	166.9	47.6	7.9	170.7		1/2	269.9	12	22.2	135
8	269.9	380	39.7	60	110	260	219.1	222.2	217.2	55.6	11.1	221.5		1/2	330.2	12	25.4	145
10	323.8	445	46.1	65	116	321	273	Threaded Flanges are furnished in NPS 1-8 only						1/2	387.4	16	28.6	165
12	381	520	49.3	71	129	375	323.8							1/2	450.8	16	31.8	180
14	412.8	585	52.4	75	141	425	355.6							1/2	514.4	20	31.8	185
16	469.9	650	55.6	81	144	483	406.4							1/2	571.5	20	34.9	195
18	533.4	710	58.8	87	157	533	457							1/2	628.6	24	34.9	205
20	584.2	775	62	94	160	587	508							1/2	685.8	24	34.9	215
24	692.2	915	68.3	105	167	702	610							1/2	812.8	24	41.3	240

CLASS 600 FLANGES

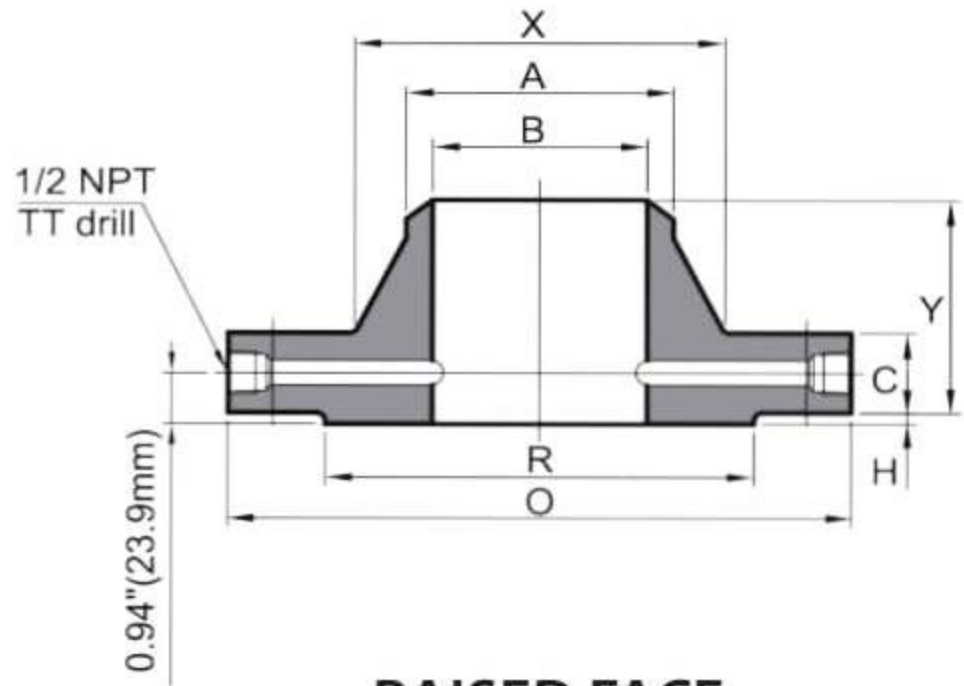

RAISED FACE

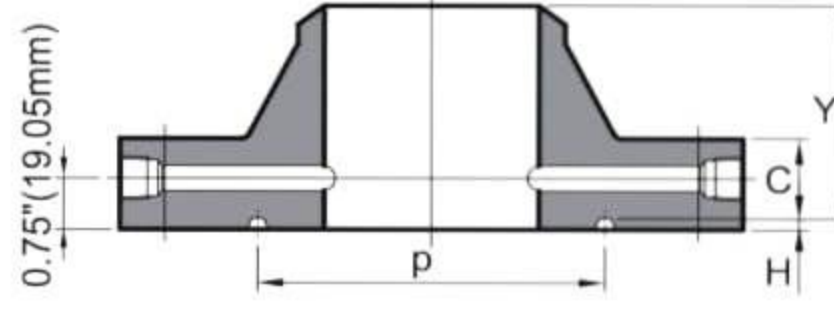

RING TYPE JOINT

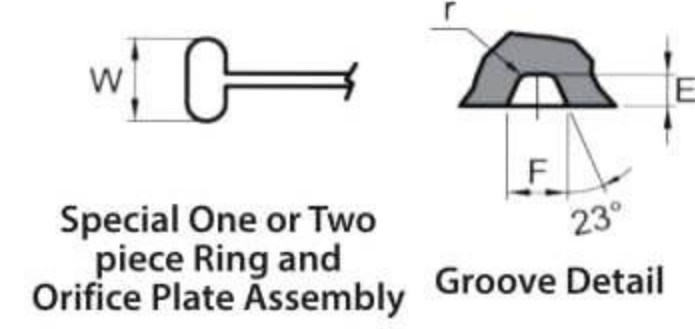

Unit : mm

Nominal Pipe Size	Ring Type Joint														Drilling Template				Length of Stud Bolts		
	O.D of Raised Face	O.D of Flange	Thick-ness of Min. Flange	Length Through Hub	Height of Raised Face	Groove Number	Pitch Diam.	Groove Depth	Groove Width	Radius at Bottom	Special Oval Ring Height	Diam. of Hub	Diam. of Hub at Bevel	Bore	Diam. of Pressure Connection (inch)	Bolt Circle Diam.	Number of Holes	Diam. Of Holes		Raised Face	Ring Joint
																		Raised Face	Ring Joint		
	R	O	C	Y	H	P	E	F	r Max.	W	X	A	B	TT							
1	50.8	125	36.6	81	2	R16	50.8	6.35	8.74	0.8	25.4	54	33.5	To be Specified by Purchaser	1/4	88.9	4	17.5	19.1	125	140
1 1/2	73	155	36.6	84	2	R20	68.27	6.35	8.74	0.8	25.4	70	48.3		1/4	114.3	4	20.7	22.2	135	140
2	92.1	165	36.6	84	2	R23	82.55	7.92	11.91	0.8	27	84	60.3		1/4	127	8	17.5	19.1	125	140
2 1/2	104.8	190	36.6	87	2	R26	101.6	7.92	11.91	0.8	27	100	73		1/4	149.2	8	22.2	22.2	135	145
3	127	210	36.6	87	2	R31	123.83	7.92	11.91	0.8	27	117	88.9		3/8	168.3	8	22.2	22.2	135	145
4	157.2	275	38.1	102	7	R37	149.23	7.92	11.91	0.8	27	152	114.3		1/2	215.9	8	25.4	25.4	150	165
6	215.9	355	47.7	117	7	R45	211.12	7.92	11.91	0.8	27	222	168.3		1/2	292.1	12	28.6	28.6	180	190
8	269.9	420	55.6	133	7	R49	269.88	7.92	11.91	0.8	27	273	219.1		1/2	349.2	12	31.8	31.8	195	210
10	323.8	510	63.5	152	7	R53	323.85	7.92	11.91	0.8	27	343	273		1/2	431.8	16	34.9	34.9	220	235
12	381	560	66.7	156	7	R57	381	7.92	11.91	0.8	27	400	323.8		1/2	489	20	34.9	34.9	230	240
14	412.8	605	69.9	165	7	R61	419.1	7.92	11.91	0.8	27	432	355.6		1/2	527	20	38.1	38.1	240	255
16	469.9	685	76.2	178	7	R65	469.9	7.92	11.91	0.8	30.2	495	406.4		1/2	603.2	20	41.3	41.3	260	276
18	533.4	745	82.6	184	7	R69	533.4	7.92	11.91	0.8	30.2	546	457.2		1/2	654	20	44.5	44.5	280	290
20	584.2	815	88.9	190	7	R73	584.2	9.53	13.49	1.5	31.8	610	508		1/2	723.9	24	44.5	44.5	300	320
24	692.2	940	101.6	203	7	R77	692.15	11.13	16.66	1.5	36.5	718	609.6		1/2	838.2	24	50.8	50.8	355	350

CLASS 900 FLANGES

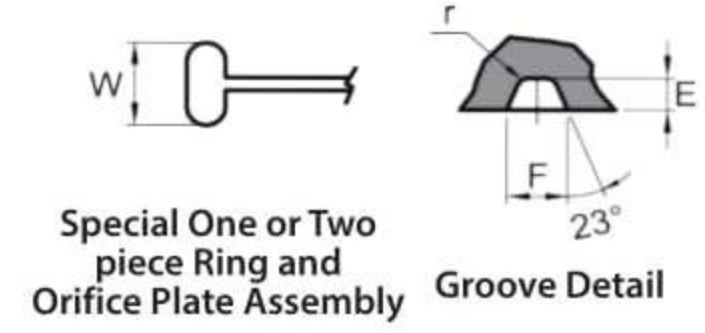
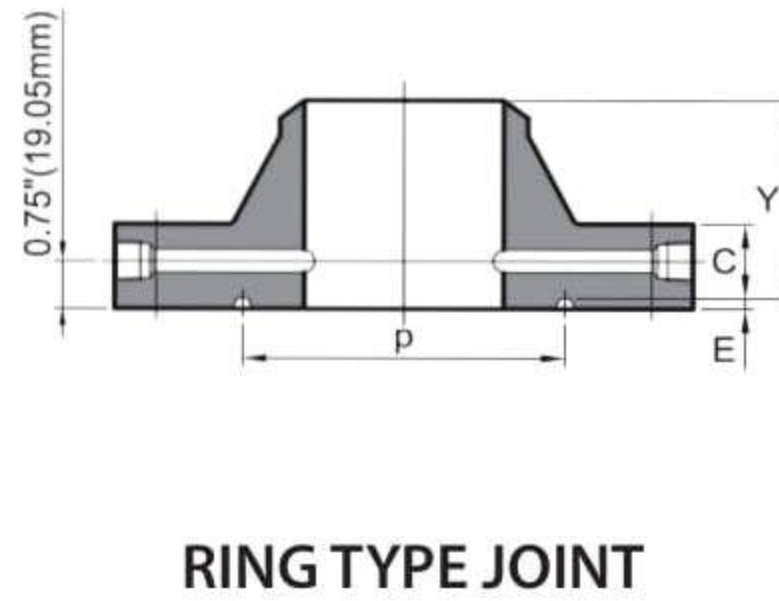
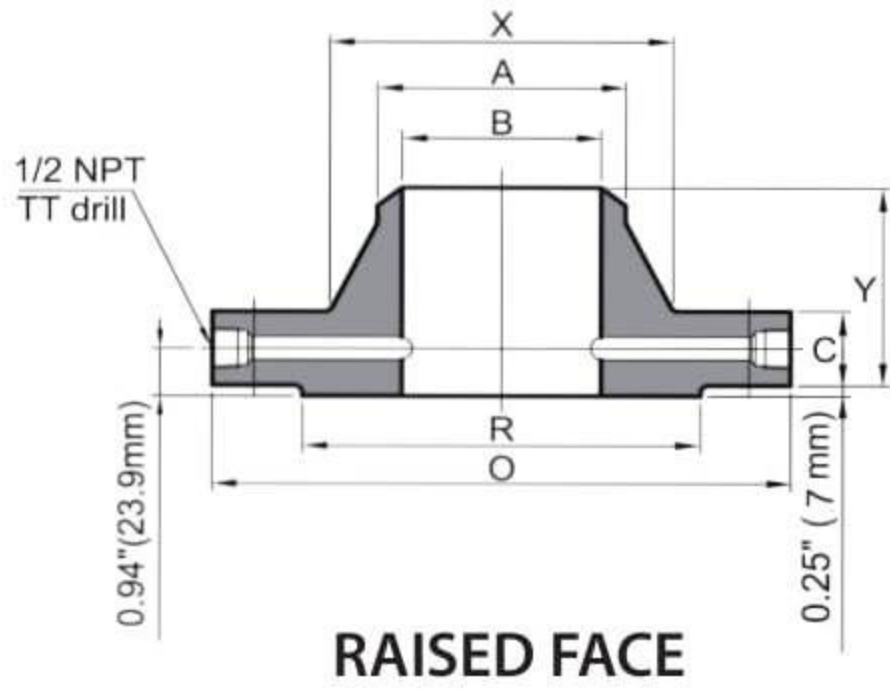

Unit : mm

Nominal Pipe Size	O.D of Raised Face	O.D of Flange	Thick-ness of Min. Flange	Length Through Hub	Ring Type Joint							Diam. of Hub	Diam. of Hub at Bevel	Bore	Diam. of Pressure Connection (inch)	Drilling Template			Length of Stud Bolts	
					Groove Number	Pitch Diam.	Groove Depth	Groove Width	Radius at Bottom	Special Oval Ring Height	Bolt Circle Diam.					Number of Holes	Diam. of Holes	Raised Face	Ring Joint	
																				R
1	50.8	150	38.1	83	R16	50.8	6.35	8.74	0.8	25.4	52	33.5	To be Specified by Purchaser	1/4	101.6	4	25.4	150	160	
1 1/2	73	180	38.1	89	R20	68.27	6.35	8.74	0.8	25.4	70	48.3		1/4	123.8	4	28.6	160	165	
2	92.1	215	38.1	102	R24	95.25	7.92	11.91	0.8	27	105	60.3		1/4	165.1	8	25.4	150	165	
2 1/2	104.8	245	41.3	105	R27	107.95	7.92	11.91	0.8	27	124	73		1/4	190.5	8	28.6	165	180	
3	127	240	38.1	102	R31	123.83	7.92	11.91	0.8	27	127	88.9		3/8	190.5	8	25.4	150	165	
4	157.2	290	44.5	114	R37	149.23	7.92	11.91	0.8	27	159	114.3		1/2	235	8	31.8	180	190	
6	215.9	380	55.6	140	R45	211.12	7.92	11.91	0.8	28.6	235	168.3		1/2	317.5	12	31.8	195	210	
8	269.9	470	63.5	162	R49	269.88	7.92	11.91	0.8	33.3	298	219.1		1/2	393.7	12	38.1	230	240	
10	323.8	545	69.9	184	R53	323.85	7.92	11.91	0.8	33.3	368	273		1/2	469.9	16	38.1	240	255	
12	381	610	79.4	200	R57	381	7.92	11.91	0.8	39.7	419	323.8		1/2	533.4	20	38.1	260	275	
14	412.8	640	85.8	213	R62	419.1	11.13	16.66	1.5	44.4	451	355.6		1/2	558.8	20	41.3	280	290	
16	469.9	705	88.9	216	R66	469.9	11.13	16.66	1.5	50.8	508	406.4		1/2	616	20	44.5	290	305	
18	533.4	785	101.6	229	R70	533.4	12.7	19.84	1.5	50.8	565	457.2		1/2	685.8	20	50.8	330	350	
20	584.2	855	108	248	R70	584.2	12.7	19.84	1.5	54	622	508		1/2	749.3	20	54	355	375	
24	692.2	1040	139.7	292	R78	692.15	15.88	26.97	2.3	58.7	749	609.6		1/2	901.7	20	66.7	445	470	

CLASS 1500 FLANGES

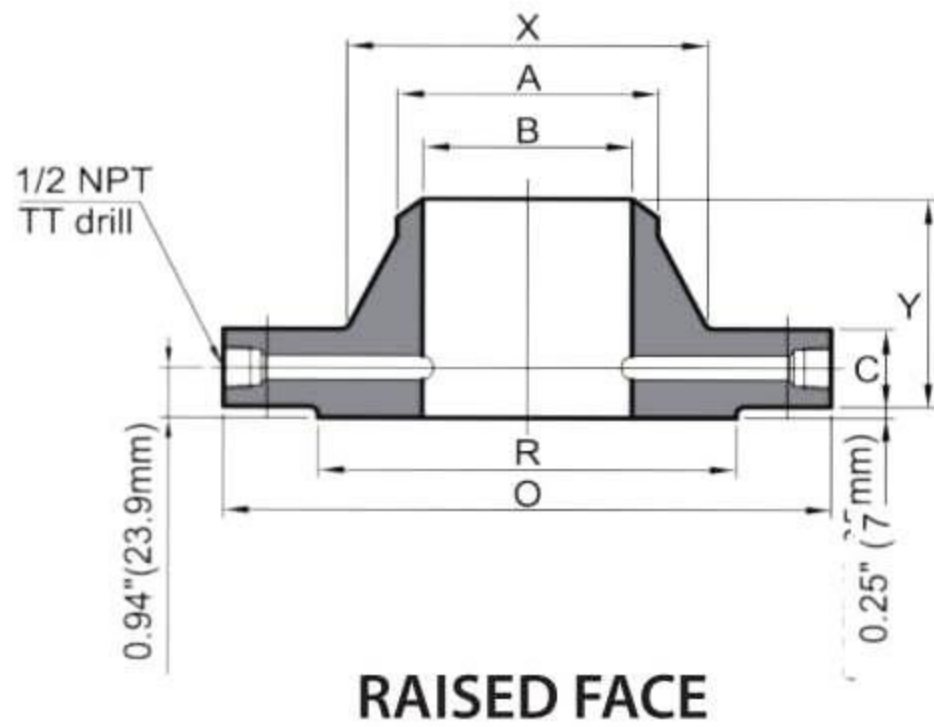

RAISED FACE

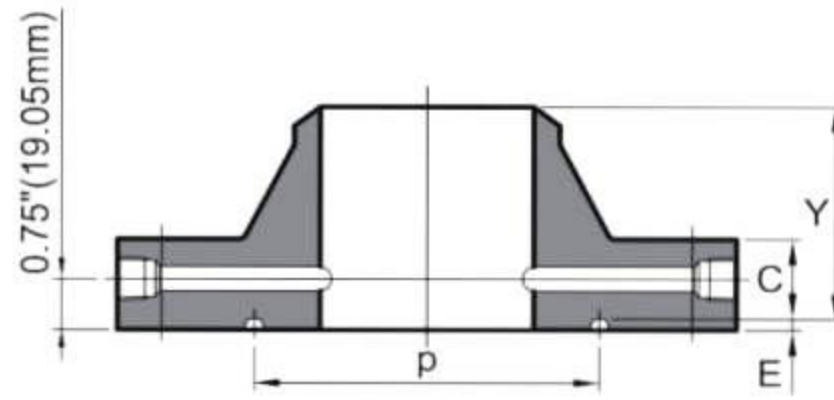

RING TYPE JOINT

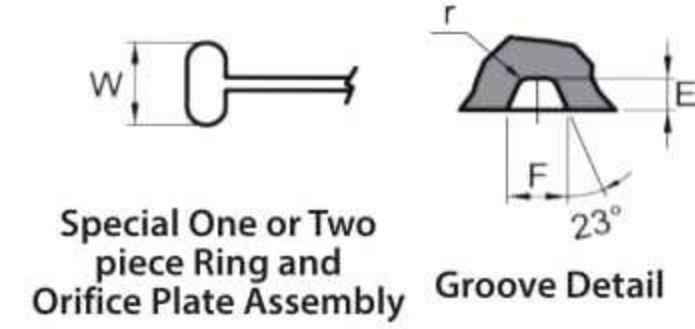

Unit : mm

Nominal Pipe Size	O.D of Raised Face	O.D of Flange	Thick-ness of Min. Flange	Length Through Hub	Ring Type Joint						Diam. of Hub	Diam. of Hub at Bevel	Bore	Diam. of Pressure Connection (inch)	Drilling Template			Length of Stud Bolts	
					Groove Number	Pitch Diam.	Groove Depth	Groove Width	Radius at Bottom	Special Oval Ring Height					Bolt Circle Diam.	Number of Holes	Diam. of Holes	Raised Face	Ring Joint
						P	E	F	r Max.	W									
1	50.8	150	38.1	83	R16	50.8	6.35	8.74	0.8	25.4	52	33.5	To be Specified by Purchaser	1/4	101.6	4	25.4	150	160
1 1/2	73	180	38.1	89	R20	68.27	6.35	8.74	0.8	25.4	70	48.3		1/4	123.8	4	28.6	160	165
2	92.1	215	38.1	102	R24	95.25	7.92	11.91	0.8	27	105	60.3		1/4	165.1	8	25.4	150	165
2 1/2	104.8	245	41.3	105	R27	107.95	7.92	11.91	0.8	27	124	73		1/4	190.5	8	28.6	165	180
3	127	265	47.7	117	R35	136.53	7.92	11.91	0.8	27	133	88.9		3/8	203.2	8	31.8	185	185
4	157.2	310	54	124	R39	161.93	7.92	11.91	0.8	27	162	114.3		1/2	241.3	8	34.9	205	215
6	215.9	395	82.6	171	R46	211.14	9.52	13.49	1.5	28.6	229	168.3		1/2	317.5	12	38.1	265	280
8	269.9	485	92.1	213	R50	269.88	11.13	16.66	1.5	33.3	292	219.1		1/2	393.7	12	44.5	300	310
10	323.8	585	108	254	R54	323.85	11.13	16.66	1.5	33.3	368	273		1/2	482.6	12	50.8	345	355
12	381	675	123.9	283	R58	381	14.27	23.01	1.5	39.7	451	323.8		1/2	571.6	16	54	380	400
14	412.8	750	133.4	298	R63	419.1	15.88	26.97	2.3	44.4	495	355.6		1/2	635	16	60.3	415	445
16	469.9	825	146.1	311	R67	469.9	17.48	30.18	2.3	50.8	552	406.4		1/2	704.8	16	66.7	450	485
18	533.4	915	162	327	R71	533.4	17.48	30.18	2.3	50.8	597	457.2		1/2	774.7	16	73	500	535
20	584.2	985	177.8	356	R75	584.2	17.48	33.32	2.3	54	641	508		1/2	831.8	16	79.4	545	570
24	692.2	1170	203.2	406	R79	692.15	20.62	36.53	2.3	58.7	762	609.6		1/2	990.6	16	92.1	620	660

CLASS 2500 FLANGES

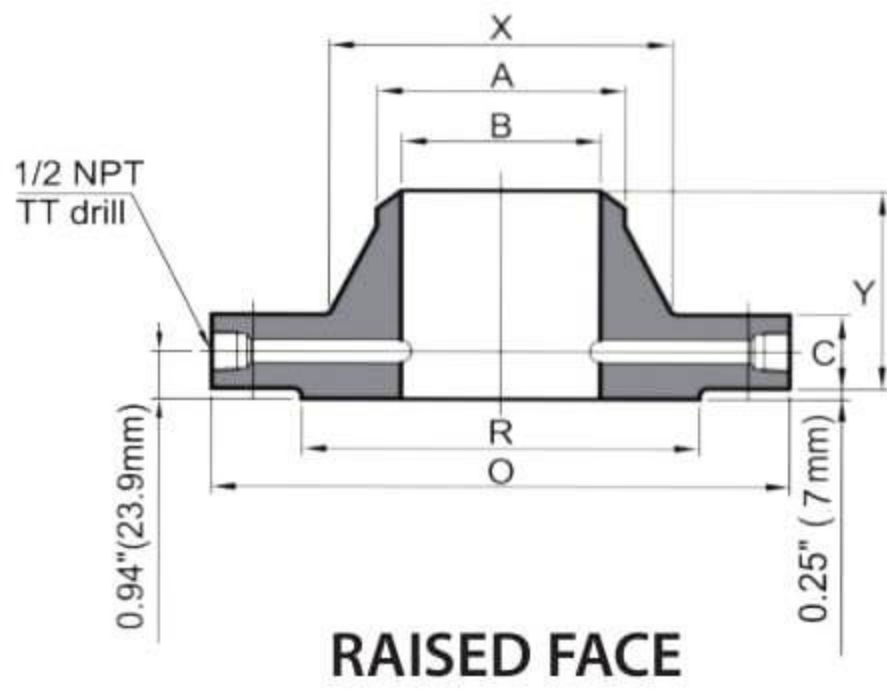

RAISED FACE

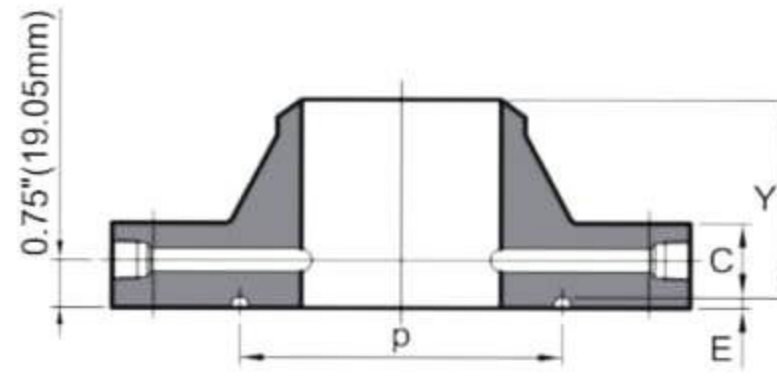

RING TYPE JOINT

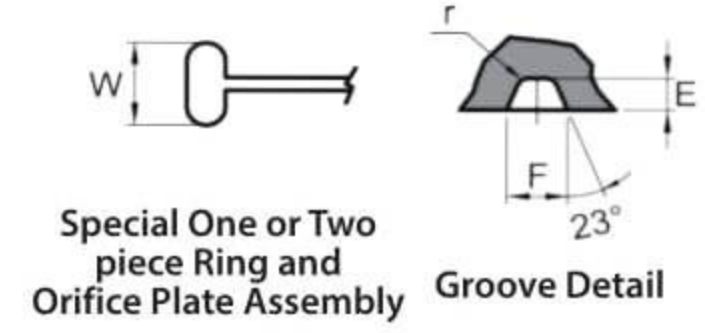

Special One or Two piece Ring and Orifice Plate Assembly

Groove Detail

Unit : mm

Nominal Pipe Size	O.D of Raised Face	O.D of Flange	Thick-ness of Min. Flange	Length Through Hub	Ring Type Joint							Diam. of Hub	Diam. of Hub at Bevel	Bore	Diam. of Pressure Connection (inch)	Drilling Template			Length of Stud Bolts	
					Groove Number	Pitch Diam.	Groove Depth	Groove Width	Radius at Bottom	Special Oval Ring Height	Bolt Circle Diam.					Number of Holes	Diam. of Holes	Raised Face	Ring Joint	
																				P
1	50.8	160	38.1	92	R18	60.33	6.35	8.74	0.8	25.4	57	33.5	To be Specified by Purchaser	1/4	108	4	25.4	150	160	
1 1/2	73	205	44.5	111	R23	82.55	7.92	11.91	0.8	27	79	48.3		1/4	146	4	31.8	180	190	
2	92.1	235	50.8	127	R26	101.6	7.92	11.91	0.8	27	95	60.3		1/4	171.4	8	28.6	185	195	
2 1/2	104.8	265	57.2	143	R28	111.13	9.53	13.49	1.5	30.2	114	73		1/4	196.8	8	31.8	205	215	
3	127	305	66.7	168	R32	127	9.53	13.49	1.5	30.2	133	88.9		3/8	228.6	8	34.9	230	240	
4	157.2	355	76.2	190	R38	157.18	11.13	16.66	1.5	33.3	165	114.3		1/2	273	8	41.3	260	275	
6	215.9	485	108	273	R47	228.6	12.7	19.84	1.5	36.5	235	168.3		1/2	368.3	8	54	350	370	
8	269.9	550	127	318	R51	279.4	14.27	23.01	1.5	39.7	305	219.1		1/2	438.2	12	54	385	405	
10	323.8	675	165.1	419	R55	342.9	17.48	30.18	2.3	47.6	375	273		1/2	539.8	12	66.7	490	515	
12	381	760	184.2	464	R60	406.4	17.48	33.32	2.3	50.8	441	323.8		1/2	619.1	12	73	540	570	